



VAF BE-Series

Automatic Brush Filter

General Information

The electric self-cleaning screen filter enables high quality filtering at degrees of 100 to 4000 micron from different types of fluid sources such as sewage, reservoirs, rivers, lakes, and wells.

Brush Filter Specifications

Materials

- Filter body • Carbon steel coated with baked on epoxy
- Screen • 316 Wedgewire or Perf.

Filtration Range • 100 to 4000 micron

Flush Volume • 70 liters (19 gallons)
(at 2 bar or 30 psi)

Max Pressure • 10 bar (150 psi)

Min Pressure • 1 bar (15 psi)

Max Temp • 65° C (150° F)

Flush Cycle • 5 to 15 seconds

Electrical

- 3-phase 0.5 hp
- Motor 220/440 VAC
- Flush Valve 24 VAC

MODEL	Nominal Flow*		Screen Area		Flg Sizes
	m ³ /hr	gpm	cm ²	in ²	
BE-500-04-XXX	80	350	2910	450	4"
BE-800-06-XXX	160	700	4190	650	6"
BE-1000-08-XXX	300	1300	5470	848	8"
BE-1100-08-XXX	430	1900	5880	911	8"
BE-1500-10-XXX	450	2000	5880	911	10"
BE-3000-12-XXX	650	2900	7630	1183	12"
BE-3300-14-XXX	900	3960	7630	1183	14"
BE-4500-16-XXX	1100	4800	11145	1728	16"

*Flow rate is based on 200 micron filtration - Wedgewire.

Flow rate increases as micron increases.

XXX = Micron size

Call VAF and discover the reasons our customers stay with us.
Wherever water Flows...

VAF Filtration Systems

5270 Marshall Street, Arvada, CO 80002 USA
Phone +1 303 425 4242 Fax +1 303 425 0112
www.valveandfilter.com
sales@valveandfilter.com

Filter Operation

Filtration

Water enters the filter through the “Inlet” (1) and passes through the fine screen (2), which purifies the flow by separating the smaller particles from the water. As more water flows through, impurities build up on the fine screen. As impurities on the screen accumulate, a pressure imbalance is built up between the internal section of the fine screen (2) and its external section.

Cleaning Process

When the difference in pressure reaches the preset value on the differential pressure indicator, or the dual time between flushing passed, a series of events is triggered while water continues to flow to the system units. The controller transmits a signal for a 10 second flushing cycle. The flushing valve (4) opens, pressure is released from the inner side of the fine screen (2), the electric motor (5) simultaneously rotates the brushes (3) around its axis. The brushes wipe all of the dirt and efficiently clean the entire internal screen (3) surface.

At the end of the 10 second cycle, the flushing valve (4) closes and the operation of the electric motor (5) is stopped. The filter is now ready for the next cycle, with clean filtered water flowing through the “Outlet” (6).

The 10 second flushing cycle resumes operation whenever the difference in pressure reaches the preset pressure value set on the differential pressure indicator. If the pressure difference remains unchanged after one cycle, another cycle will start after a delay of 10 seconds.

- | | |
|----------------|-------------------|
| 1. Inlet | 4. Flushing Valve |
| 2. Fine Screen | 5. Electric Motor |
| 3. Brush | 6. Outlet |

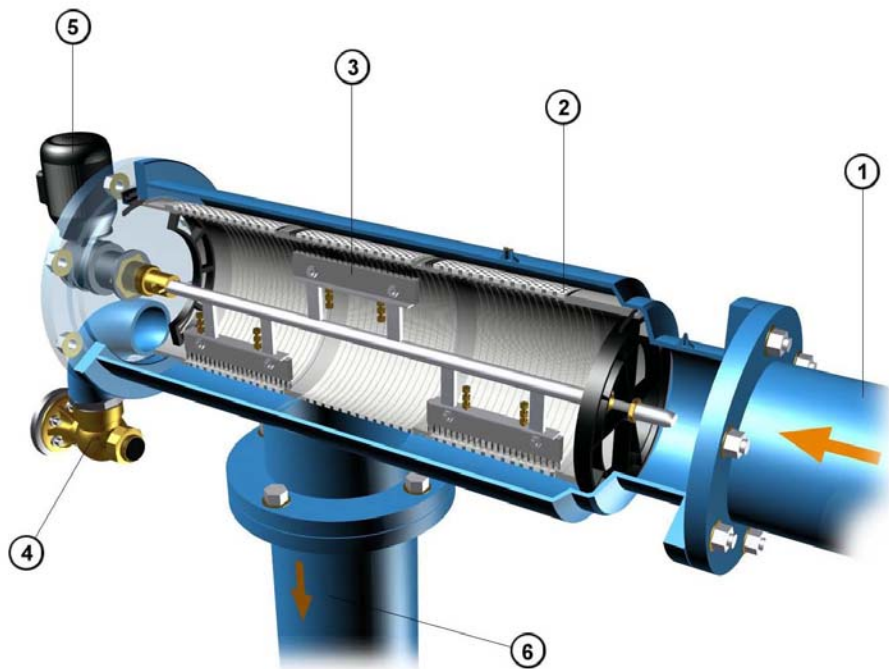

VAF Filtration Systems

5270 Marshall Street, Arvada, CO 80002 USA

Phone +1 303 425 4242 Fax +1 303 425 0112

www.valveandfilter.com

sales@valveandfilter.com