



VALVE AND FILTER CORPORATION

V SERIES AUTOMATIC FILTER

How It Works

Please refer to the cutaway of the “V” series filter shown.

Dirty water enters the filter through the inlet (1) and then passes through the coarse screen (2) from the outside in. It flows from the inside of the coarse screen to the inside of the fine screen and then passes through the fine screen (3) from the inside out. Dirt is collected on the inside surface of the fine screen. The clean filtered water then exits through the filter outlet (4) and on to the system.

As the dirt or cake builds up on the inside surface of the fine screen, the pressure drop across the screen increases. When the pressure drop, (the DP or differential pressure) reaches a preset level (7 psi), the filter controller starts a flush cycle by opening a flush valve on the flush line (5). This flush valve exhausts the drive chamber to atmosphere at “0” psi.

The flush line (5) is connected to the drive chamber which is separated from the filtration chamber by a drive chamber partition (6). However, the dirt collector (7) (a hollow pipe with dirt collector nozzles) extends through the partition (6), thus providing a “path” from the dirt collector nozzles (8) through the hydraulic drive (9), into the drive chamber and out the flush line (5) to atmosphere. The pressure around the dirt collector nozzle (8) is the pressure inside the filter and as water flows through the “path”, it drops to “0” psi when it leaves the flush line (5). This creates an aggressive “suction” at the dirt collector nozzle (8) opening. The dirt collector nozzle (8) clearance at the fine screen (3) is very small. So, the extreme low pressure at the nozzle opening creates a backflow which “sucks” the dirt from the fine screen (3).

The hydraulic drive (9) has jets on opposite sides near it’s ends. Water jetting out of these openings (coming from the dirt collector nozzles (8)) creates a reaction force (like a pin wheel) which rotates the drive (9) and the dirt collector (7). As the dirt collector (7) rotates, each dirt collector nozzle (8) cleans a band on the fine screen (3).

As the dirt collector (7) rotates, the reverser (10) (works like the level winder on your fishing reel) causes the hydraulic drive (9) / dirt collector (7) / dirt collector nozzle (8) assembly to move back and forth. The rotation governor (11) helps control the rotation speed of the dirt collector (7) assembly. The balance piston (12) helps balance the transverse pressure on the assembly, and powers the reverser indicator (13) which provides visual indication of the dirt collector (7) assembly movement showing that the entire cleaning system is operating properly during the rinse cycle.

After a preset time, the flush valve closes and the rinse cycle is complete. Very little rinse water is used for each rinse. Please note the filter continues to supply water to the system during the rinse cycle.

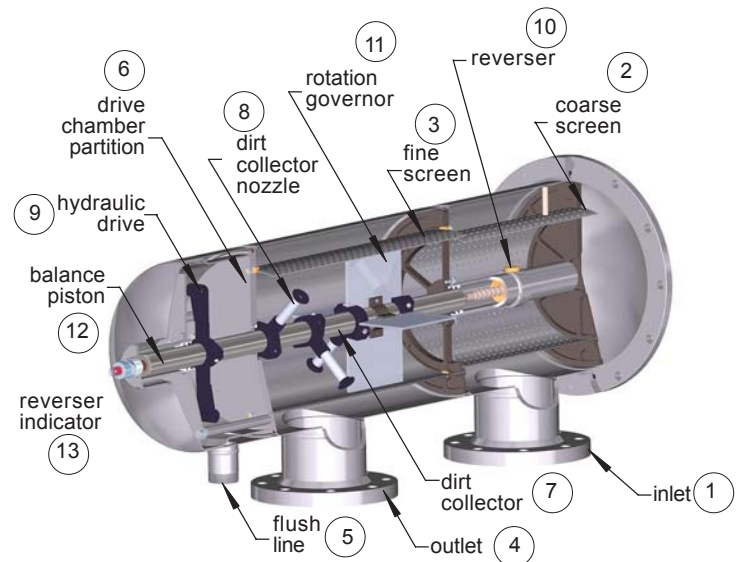

Valve and Filter

5270 Marshall Street, Arvada, CO 80002 USA
Phone 303-425-4242 Fax 303-425-0112
www.valveandfilter.com
sales@valveandfilter.com



V SERIES AUTOMATIC FILTER

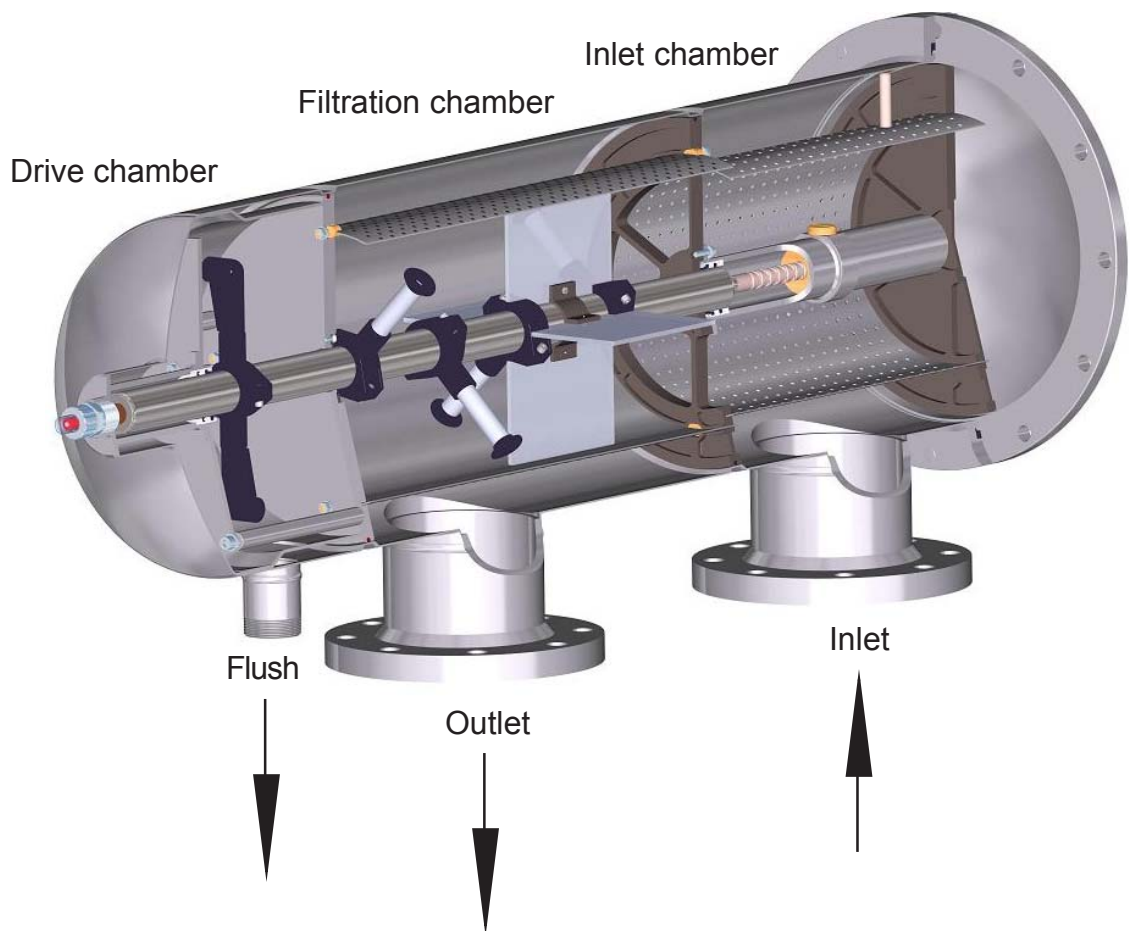

Valve and Filter

5270 Marshall Street, Arvada, CO 80002 USA
Phone 303-425-4242 Fax 303-425-0112
www.valveandfilter.com
sales@valveandfilter.com